



Subject Index



1. Technical Data
2. Hints
 - 2.1. General Hints
 - 2.2. Warning and Safety Hints.
 - 2.3. General Hints to Danger.
 - 2.4. Proper use.
3. Storage.
4. Assembly.
 - 4.1. Coupling components.
 - 4.2. Hints regarding the finish bore.
 - 4.3. Taper lock clamping Sleeve.
 - 4.4. Assembly of the hubs.
 - 4.5. Alignment of the couplings.
5. Hints and instructions regarding the use in Ex. hazardous areas.
 - 5.1. Control intervals for couplings in Ex. hazardous areas.
 - 5.2. Approximate values of wear.
 - 5.3. Permissible coupling materials in Ex. hazardous areas.
 - 5.4. Ex Marking of the coupling for Ex. hazardous areas.
 - 5.5. Starting.
 - 5.6. Breakdowns, causes and elimination.
 - 5.7. Certificate of Conformity according to Directive 2014/34/EU of 26th February 2014.
 - 5.8. Assembly and alignment instructions in Ex. areas.

1. Technical Data

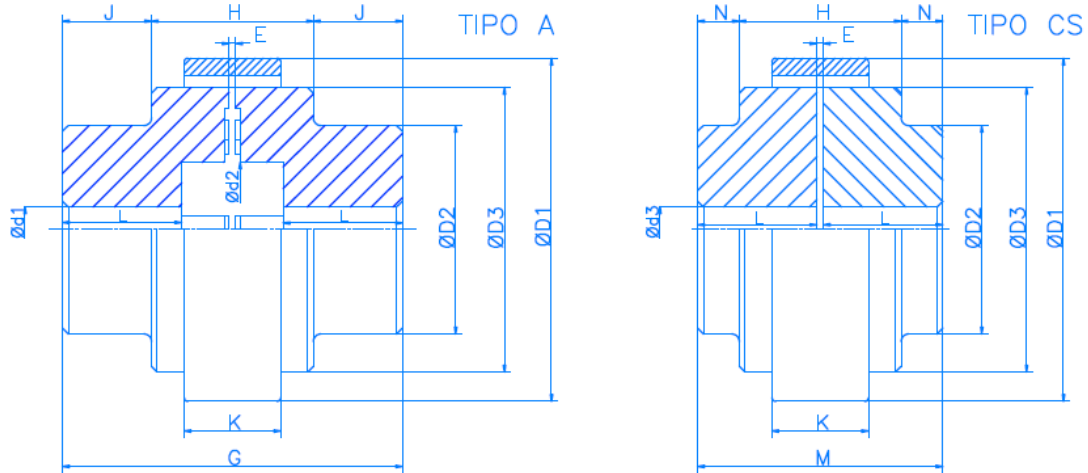

TABLE 1

Samiflex coupling Type A

Size	Samiflex insert STD Yellow Torque (Nm)		r.p.m*	Ø d1 (mm)		DIMENSIONS IN mm.									
	Nominal	Maximum		Pre Ø	Ø Max	G	L	Ød2	D1	D2	D3	K	J	H	E
A00	6.5	20	16.000	4	16	51	19	22	44	35	35	12	-	-	1,5
A0	22	55	11.000	8	24	73	28	32	65	52	52	16	-	-	1,5
A1	55	138	8.800	14	38	91	34	39	83	65	65	22	-	-	1,5
A2	110	275	6.500	17	44	127	47	45	111	80	86	32	36	55	2,5
A3	220	550	4.900	19	50	156	56	52	144	85	116	42	45	65	2,5
A3B	220	550	4.900	19	58	156	56	52	144	105	116	42	45	65	2,5
A4	460	1.150	3.800	24	65	180	63	70	182	110	150	51	47	85	3,5
A4B	460	1.150	3.800	24	70	180	63	70	182	135	150	51	47	85	3,5
A45	805	2.013	3.300	25	75	198	70	90	202	125	170	56	52	93	3,5
A5	1.150	2.875	3.000	29	85	216	77	89	225	140	190	59	57	101	3,5
A55	1.725	3.450	2.650	30	95	246	90	115	250	155	215	64	68	109	3,5
A6	2.300	4.600	2.450	39	110	260	95	112	265	180	233	67	70	119	3,5
A7	4.600	9.200	2.100	48	130	310	116	135	306	205	267	75	88	134	4
A8	8.625	17.250	1.750	63	150	382	147	157	363	242	326	85	114	154	5
A9	13.750	27.500	1.450	73	180	420	162	188	425	280	385	92	129	162	5
A10	27.500	44.000	1.175	96	210	482	188	218	523	330	483	102	145	192	6
A11	36.750	58.800	1.650	96	210	512	190	216	503	350	458	128	148	216	6
A12	100.000	160.000	1.175	100	300	709	250	380	710	500	650	210	175	359	5

Samiflex coupling Type CS

Size	Samiflex insert STD Yellow Torque (Nm)		r.p.m*	Ø d3 (mm)		DIMENSIONS IN mm.								
	Nominal	Maximum		Pre Ø	Ø Max	M	L	D1	D2	D3	K	N	H	E
A1CS	55	138	8.800	14	28	73	34	83	65	65	22	-	-	1,5
A2CS	110	275	6.500	17	35	97	47	111	80	86	32	20,4	55	2,5
A3CS	220	550	4.900	19	42	115,5	56	144	85	116	42	24,7	65	2,5
A4CS	460	1.150	3.800	24	55	129,5	63	182	110	150	51	22	85	3,5
A45CS	805	2.013	3.300	25	65	143,5	70	202	125	170	56	25	93	3,5
A5CS	1.150	2.875	3.000	29	75	157,5	77	225	140	190	59	28,2	101	3,5
A55CS	1.725	3.450	2.650	30	85	184	90	250	155	215	64	37,2	109	3,5
A6CS	2.300	4.600	2.450	39	90	194	95	265	180	233	67	37,2	119	3,5
A7CS	4.600	9.200	2.100	48	110	236	116	306	205	267	75	51	134	4
A8CS	8.625	17.250	1.750	63	130	299	147	363	242	326	85	72,5	154	5
A9CS	13.750	27.500	1.450	73	160	382	162	425	280	385	92	118	162	5
A10CS	27.500	44.000	1.175	96	190	386	188	523	330	483	102	95	192	6
A11CS	36.750	58.800	1.650	96	190	505	190	503	350	458	128	85	216	6
A12CS	100.000	160.000	1.175	100	300	382	250	710	500	650	210	148	359	5



1. Technical Data

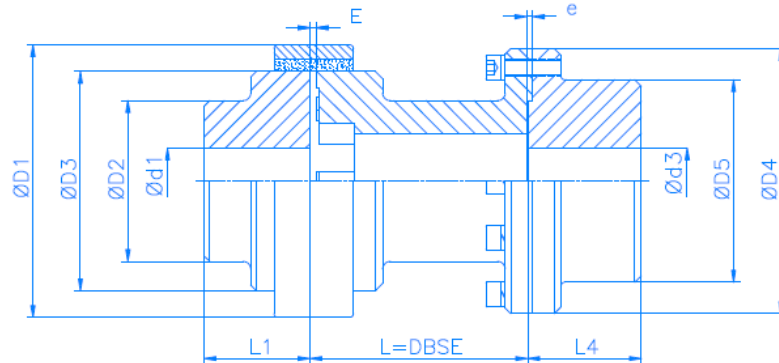

TABLE 2

Size	Insert 95° Shore A Torque (Nm)		Bore Ø (mm.)			r.p.m	Dimensions in mm.									
	Nominal	Maximum	Pre Ø	Ø Max. d1	Ø Max d3		D1	D2	D3	D4	D5	E	e	L1	L4	L(DBSE)
A1CS	55	138	14	28	42	5.500	83	65	65	100	67	3.0	2.0	34	37	100 120 140
A2CS	110	275	17	35	48	4.750	111	80	86	120	83	3.0	2.0	47	54	100 120 140
A3CS	220	550	19	42	65	4.000	144	85	116	140	107	3.5	2.5	56	60	100 120 140
A4CS	460	1.150	24	55	85	3.200	182	110	150	178	140	3.5	2.5	63	65	120 140 180
A45CS	805	2.013	25	65	90	2.850	202	125	170	200	150	3.5	2.5	70	75	120 140 180
A5CS	1.150	2.875	29	75	110	2.500	225	140	190	225	179	3.5	2.5	77	79	140 180 200
A55CS	1.725	3.450	30	75	110	2.300	250	155	215	245	180	4.0	3.0	90	95	140 180 200
A6CS	2.300	4.600	39	90	120	2150	265	180	233	265	198	4.0	3.0	95	95	180 200 250
A7CS	4.600	9.200	48	110	130	1.975	306	205	267	290	220	4.0	3.0	116	120	200 250 280
A8CS	8.625	17.500	63	120	160	1.600	363	242	326	360	250	5	3	147	147	250

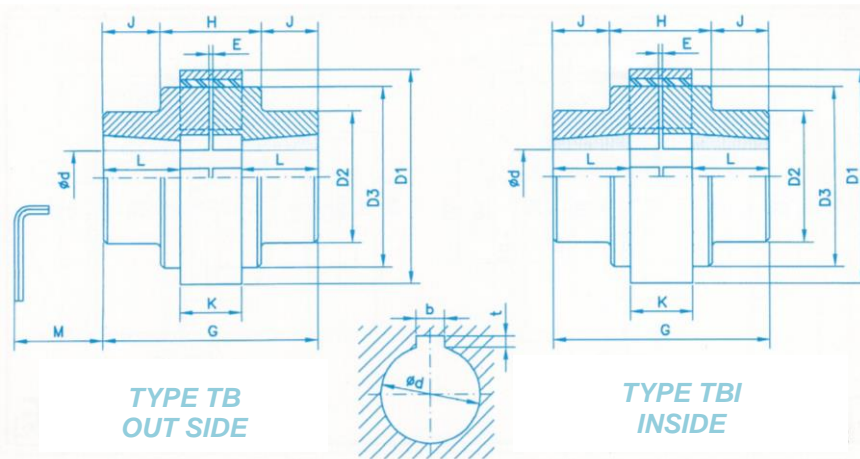

TABLE 3

Size	Taper bush	MIN	MAX.	L	G	E	K	H	D1	D2	D3	J	M
		Ød1	Ød1										
		mm.	mm.										
A1 - TB/TBI	1108	9	28	27	77	1,5	22	-	83	65	65	-	29
A2 - TB/TBI	1210	11	32	32	97	2,5	32	55	111	80	86	21	38
A3 - TB/TBI	1610	14	42	32	107	2,5	42	65	144	85	116	21	38
A4 - TB/TBI	2012	14	50	38	130	3,5	51	85	182	110	150	22	42
A45 - TB/TBI	2517	16	60	50	158	3,5	55	93	202	125	170	32	50
A5 - TB/TBI	3020	25	75	56	173	3,5	59	101	225	140	190	36	55
A6 - TB	3535	35	90	95	259	3,5	67	119	265	180	233	70	67
A7 - TB	4040	40	100	107	292	4	75	134	306	205	267	79	70

2. Hints

2.1 General Hints

Please read the assembly instructions carefully before starting to operate the coupling. Pay particular attention to the safety instructions.



The Samiflex coupling is approved for use in hazardous areas.

When using the coupling in hazardous areas, pay special attention to the Safety Instructions in our Section A.

The assembly instructions are part of your product, and should be kept with the coupling at all times until it is assembled.

Keep these instructions in a safe place, so they can be referred to by maintenance personnel.

2.2.2 Safety and Advise Hints



Danger !

Danger of injury to persons.



Caution !

Damages on the machine possible.



Attention !

Pointing to important items.



Caution !

Hints concerning explosion protection.

2.3 General Hints of Danger



Danger !

With assembly, operation and maintenance of the coupling, make sure that the entire drive train is protected against unintentional engagement. Serious injuries can occur from rotating parts. Likewise, make sure to read through and observe the following safety instructions:

- All operations on and with the coupling must be performed with “safety first” being the primary consideration.
- Make sure to disengage the power pack before you perform your work.
- Protect the power pack against unintentional engagement, for example, by providing hints at the place of engagement, or removing the power supply fuse.
- Do not touch the coupling’s working area while it is operating.
- Protect the coupling against unintentional touch. Provide the necessary protective covers and devices.

2.4. Proper Use

Assembly, operation and maintenance work may be performed on the coupling only if:

- The assembly instructions are read carefully and understood.
- The personnel is technically qualified.
- Are authorized to do so by the company.

The coupling may only be used in accordance with the technical data (see table 1 to 8)

Unauthorized modifications to the coupling are not admissible. We decline any warranty due to consequent damage. For future development of the product, we reserve the right to make technical modifications.

The Samiflex coupling described here corresponds to the technical status at the time of printing these assembly instructions.

3. Storage

The couplings' hubs and rings are supplied in storable conditions, and can be stored in a dry, covered place for an indefinite time.

The elastic inserts remain unchanged for an indefinite time, retaining their mechanical and hardness characteristics. Light causes a colour change in the elastic inserts following a prolonged period of storage (over 3 years).

4. Assembly

Basically, the coupling is supplied assembled in boxes with type identification. If the coupling is supplied in separate parts, a check should be made prior to assembly, to ensure it is complete.

4.1. Coupling components

Components of Samiflex coupling type A y CS.

Component	Quantity	Designation
1	2	Hub
2	1	Elastic insert
3	1	Ring
4	2	Locking set screw
5	2	Set screw

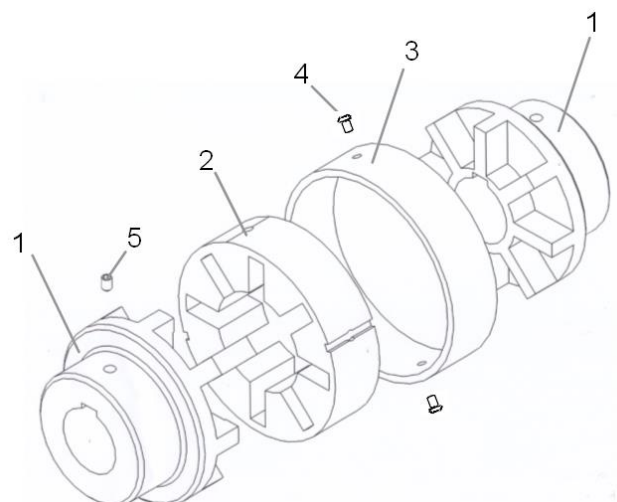

Components of Samiflex coupling type CS with Spacer

Component	Quantity	Designation
1	1	Hub
2	1	Flange Hub
3	1	Spacer body
4	1	Elastic Insert
5	1	Ring
6	2	Locking set screw
7	6-8	Cap Screw
8	2	Set Screw

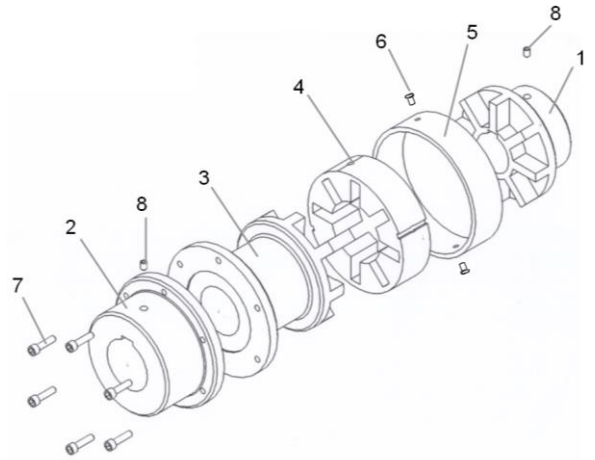

Components of Samiflex coupling type A with taper lock.

Component	Quantity	Designation
1	2	Hub TB / TBI
2	1	Elastic Insert
3	1	Ring
4	2	Locking set screw.
5	2	Taper lock
6	4	Set screw

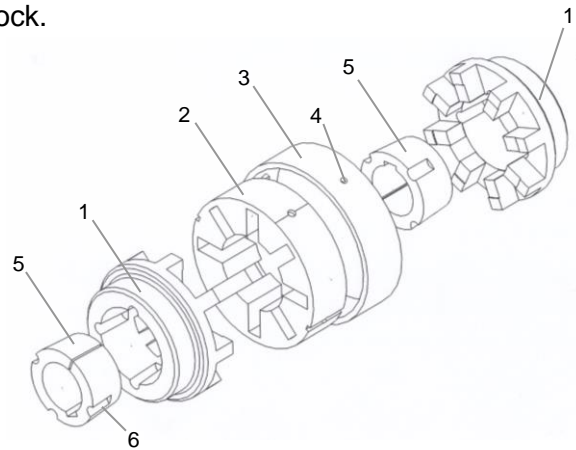

Elastic Insert / Material: Poliurethane

QUALITY	REF.	HARDNESS	COLOUR	TEMP. RATING
STANDARD	STD	80 SHORE A	BLUE	- 40 / 80° C
		95 SHORE A	YELLOW	
HIGH TEMP.	HT	95 SHORE A	ORANGE	- 40 / 140° C
HIGH PERFORMANCE	HD	97 SHORE A	BROWN	- 40 / 80° C
	HDT	97 SHORE A	RED	- 40 / 140° C

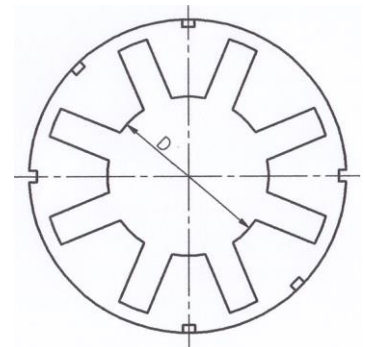

TABLE 4

SIZE	A00	A0	A1	A2	A3	A4	A45	A5	A55	A6	A7	A8	A9	A10	A11	A12
D (mm).	22	32	40	48	58.5	76	94	106.5	119	127	162	194	233	275	248	390

Rings

TYPE	A00	A0	A1	A2	A3	A4	A45	A5	A55	A6	A7	A8	A9	A10	A11	A12
STEEL	●	▲	▲	▲	▲	▲	●	●	●	●	●	●	●	●	●	●
POLYAMIDE	-	●	●	●	●	●	-	-	-	-	-	-	-	-	-	-

● SUPPLIED AS STANDARD ▲ SUPPLIED UNDER REQUEST - NOT AVAILABLE

4.2. Hints regarding the finish bore



Danger !

¡ Valid for all materials !

The maximum permissible diameters d (see table 1 - technical data) must not be exceeded. In the event of failure to keep to these values, the hub may break and the particles dispersed by the rotation may cause serious danger.

Hub bores machined by the customer, have to observe concentric running or axial running respectively (see figure 1)

Secure the set screw with the tightening torque indicated in table 5. For maximum safety against spontaneous loosening, we recommend using medium grade loctite.

$\varnothing d$		TABLE 5	
OVER mm.	TO mm.	G	(Nm) TORQUE
10	24	M4	1.5
24	38	M6	4.8
38	48	M8	10
48	65	M10	17
65	90	M12	40
90	130	M16	80
130	170	M20	140
170	200	M22	210
200	245	M24	220
245	300	M24*	220

*2 off set screws

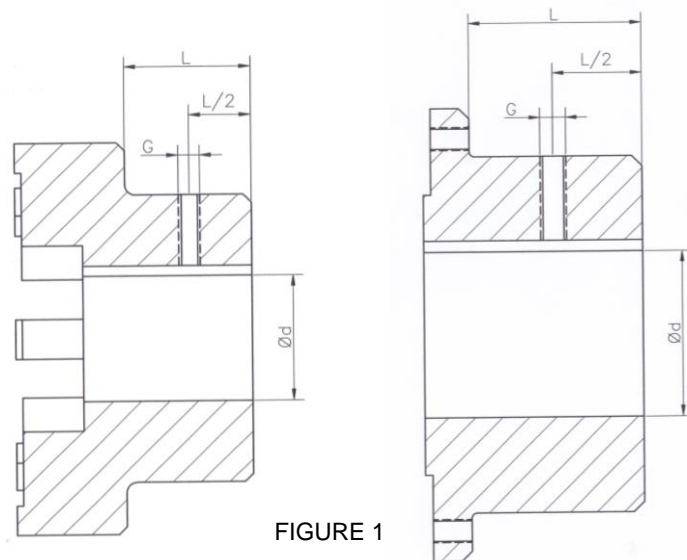

FIGURE 1

4.3. Taper lock Clamping sleeve

Assembly of the taper lock-clamping sleeve:

The taper lock clamping sleeve has cylindrical and even pocket holes parallel to the axis. Only half to these holes are in the material of the sleeve. The other half located at the hub has convolutions.

Push the coupling hub and the taper lock clamping sleeve into each other, make holes onto the cover and tighten the grub screw slightly.

TABLE 6

COUPLING	A1 TB/TBI	A2 TB/TBI	A3 TB/TBI	A4 TB/TBI	A45 TB/TBI	A5 TB/TBI	A6 TB	A7 TB
TAPER LOCK	1108	1210	1610	2012	2517	3020	3535	4040
TORQUE (Nm)	5.6	20	20	30	50	90	115	192



Dissassembly of the taper lock –clamping sleeve:

By removing the grub screws you can detach the taper lock clamping sleeve. Afterwards, one of the grub screws is screwed into the thread of the sleeve as forcing screw and tightened.

The detached coupling hub can be manually taken off the shaft with the taper lock clamping sleeve.

4.4. Assembly of the hubs



Attention !

We recommend to check bores, shaft, key-way and the feather key for dimensional accuracy before assembly.

The hubs can be fitted on the shafts by interference (heating up the hubs), or by clearance them, using the appropriate lubricants.



Caution !

Take care with the danger of ignition in hazardous areas.



Caution !

For the assembly, make sure that distance E (see table 7) is kept, in order to ensure that the elastic insert can be fitted. Respect axial tolerance X (see table 7) of the hubs.

Failure to follow this recommendation may result in damage to the coupling.

- Assemble the hubs onto the shaft of driving and driven side.
- Move the power packs in axial direction until the dimension E is achieved. (respect maximum axial tolerance X).
- If the power packs are already firmly assembled, axial movement of the hubs on the shafts allows for adjusting the dimension E.
- Fasten the hubs by tightening the setscrews DIN 7380 with cup point.

Attention !

If the shaft diameters with the inserted feather key are smaller than the dimensions D (see table 4) of the elastic insert, one or two shafts ends may protrude into the insert.



4.5. Alignment of the couplings

In order to ensure a long lifetime of the coupling and to avoid dangers regarding the use in hazardous areas, the ends of the shaft must be aligned with precision.

Keep to the alignment measurements and maximum admissible tolerances in table 7.

In case of a use in hazardous areas for the explosion group II C (marked II 2G c T4), assembly measurement E, all the alignment values and the maximum admissible axial tolerance must be kept to with absolute precision.

TABLE 7

ASSEMBLY DIMENSIONS AND TOLERANCES IN M.M.																
TYPE	A00	A0	A1	A2	A3	A4	A45	A5	A55	A6	A7	A8	A9	A10	A11	A12
E assembly	1.5	1.5	1.5	2.5	2.5	3.5	3.5	3.5	3.5	3.5	4	5	5	6	6	5
Axial X	+0.3	+0.3	+0.5	+0.5	+0.7	+0.8	+1.0	+1.0	+1.0	+1.0	+1.0	+1.5	+1.5	+2	+2	+3
Radial Y rpm < 3000	0.2	0.3	0.3	0.5	0.5	0.7	0.7	0.7	0.8	0.8	1.0	1.0	1.0	1.5	1.5	0,6
Radial Y rpm > 3000	0.10	0.10	0.10	0.10	0.15	0.20	0.20	0.20	0.20	0.20	0.30	0.30	-	-	-	-
Angular Z	0.10	0.10	0.20	0.20	0.30	0.40	0.40	0.50	0.50	0.60	0.90	1.10	1.30	1.70	1.70	2,00

The values in table 7 are maximum figures which should not appear at the same time. If radial and angular misalignment are present at the same time, the permissible displacement values can only be used partially (see figure 2).

Example for such a combination
of misalignments given in figure 2

Example 1: Example 2:
Y = 40% Y = 20%
Z = 60% Z = 80 %

Formula: $\Delta_{total} = \Delta Y + \Delta Z \leq 100\%$

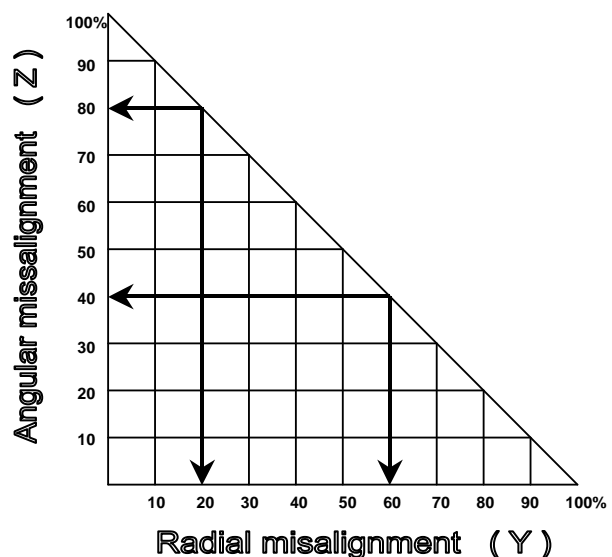

FIGURE 2

5. Hints and instructions regarding the use in Ex hazardous areas



5.1. Control intervals for couplings in Ex. hazardous areas.

explosion group	Control intervals
II 2G c IIB T4	<p>The elastic insert should be checked after 3000 hours of operation the first time, or after 6 months at the latest. If insignificant or no wear and tear is observed in the elastic insert following this first inspection, the following inspections can be carried out, provided the operating parameters are the same, after 6000 hours of operation, or after 18 months at the latest, respectively.</p> <p>If considerable wear and tear is observed during the first inspection, so that it would be advisable to change the elastic insert, the cause should be determined, in accordance with the breakdowns table. Maintenance intervals must be adjusted according to the changed operating.</p>
II 2G c IIC T4	<p>The elastic insert should be checked after 2000 hours of operation the first time, or after 6 months at the latest. If insignificant or no wear is observed in the elastic insert following this first inspection, the following inspections can be carried out, provided the operating parameters are the same, after 4000 hours of operation, or after 12 months at the latest, respectively.</p> <p>If considerable wear is observed during the first inspection, so that it would be advisable to change the elastic insert, the cause should be determined, in accordance with the breakdowns table. Maintenance intervals must be adjusted according to the changed operating.</p>

5.2. Approximate wear values.

The elastic insert can be inspected easily during a stoppage of the equipment, by displacing the ring axially, once the two attachment set screws have been removed.

The half-life of the elastic insert under normal working conditions is 25,000 hours. As a preventive measure, the elastic insert should be inspected after the first 3000 operating hours (see table 8).

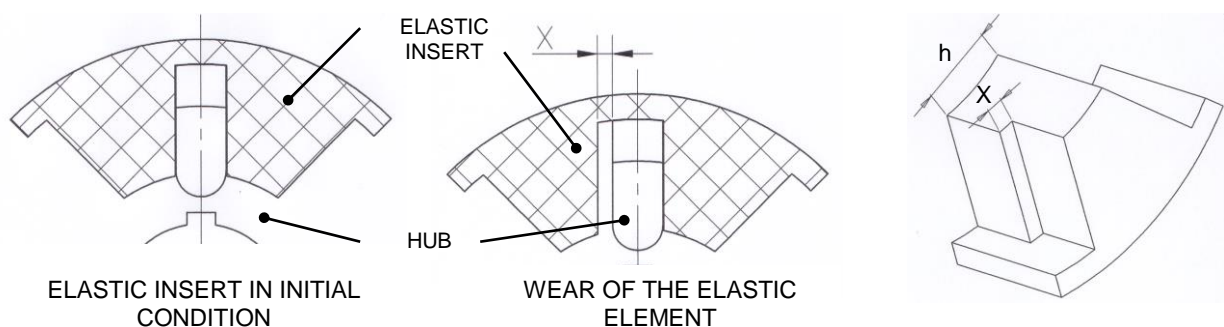

When the figure X (mm) for wear and tear by friction of the elastic insert reaches the values set out in table 8, it should be replaced with a new one. In the event it is not replaced, the elastic insert could break due to shearing, leaving the equipment switched off on the drive / power side.

TABLE 8

TIPO	A00	A0	A1	A2	A3	A4	A45	A5	A55	A6	A7	A8	A9	A10	A11	A12
h	7	7	8.5	11	14.5	15	21	22	27	28	36	37.5	42	47	60	101.7
X (mm)	1.5	1.5	2.0	2.5	3.0	3.0	4.0	4.5	5.5	6.0	7.5	7.5	8.5	9.5	10	17

5. Tips and instructions regarding the use in Ex hazardous areas



5.3. Permissible coupling materials in Ex hazardous areas

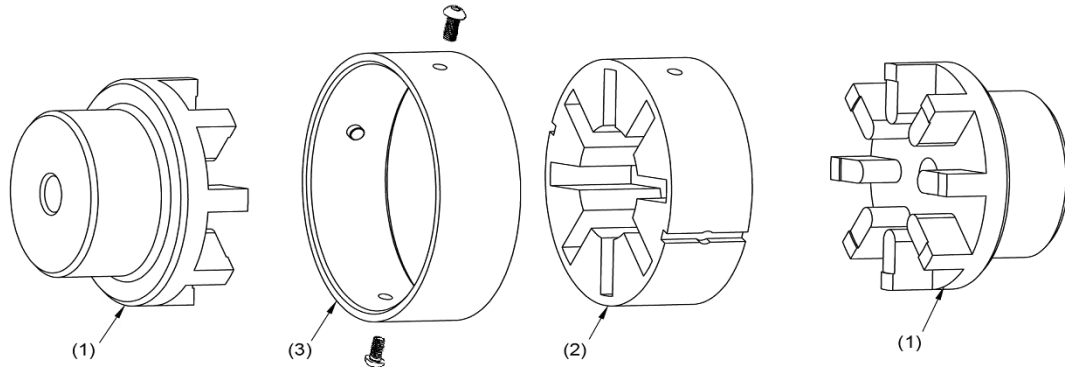

TYPE	A00	A0 – A1 – A2 – A3 – A4	A45 – A5 – A55	A6 – A7 – A8 – A9 – A10 – A11 – A12
HUB (1)	DURALUMINIO	GG25 GGG40 STEEL F114 INOX AISI 304	GG25 GGG40 STEEL F114	GG25 GGG40
INSERT (2)	POLIURETHANE	POLIURETHANE	POLIURETHANE	POLIURETHANE
RING (3)	STEEL	POLYAMIDE STEEL	STEEL	STEEL

COUPLING MATERIALS ADMITTED IN HAZARD AREAS



explosion group	Permissible coupling materials / TYPE
IIB	Samiflex coupling A0 to A4 with polyamide attachment ring
IIC	Samiflex coupling A0 to A3 with polyamide attachment ring Samiflex coupling A0 to A12 with steel attachment ring

Aluminium as coupling material is generally excluded for explosive areas.

5.4. Ex marking of the coupling for Ex. hazardous areas.

Couplings for use in hazardous areas are marked with regard to the respective permissible conditions of use.

Explosion group IIC: e.g.: II 2G c IIC T4

Explosion group IIB is included in the II 2G c IIC T4 marking.

5.5 Starting

CAUTION !

The equipment (motor) must not be started up without having first fitted (assembled) the attachment ring to the elastic insert, securing it with the two attachment set screws.

The elastic insert is projected out of the hubs, if the equipment (motor) is started up without the attachment ring having first been fitted (assembled).



5. Hints and instructions regarding the use in Ex hazardous areas



5.5 Starting

Before starting up the coupling, the protective cover must be fitted.

Rotary equipment is potentially dangerous and can cause serious injury.

It is the user's responsibility to provide adequate protection, in compliance with standards for the speed and applications in which are used.

CAUTION

If you note any irregularities at the coupling during operation, the drive unit must be turned off immediately. The cause of the breakdown must be found out with the table "Breakdowns" and, if possible, be eliminated according to the proposals. The possible breakdowns mentioned can be hints only. To find out the cause all operating factors and machine components must be considered.

COUPLING PROTECTION IN Ex. HAZARDOUS AREAS

The coupling must be fitted with firm metal covers protecting it against falling objects. The distance between the cover and the rotating parts must be at least 5 mm. The cover must be an electrical conductor and be included in the equipotential connection. Bellhousing made from aluminium and damping ring (NBR) can be used as connecting elements between the pump and the electric motor, if the magnesium part is below 7.5%. The cover may be removed only after the unit has been stopped.

5. Hints and instructions regarding the use in Ex hazardous areas



5.6. Breakdowns, Causes and Elimination

BREAKDOWNS	CAUSES	DANGER HINTS FOR HAZARDOUS AREAS	ELIMINATION
Change of the running noises and/or occurring vibrations.	Misalignment micro friction at the toothing of the elastic insert.	Danger of ignition due to hot surfaces.	<ol style="list-style-type: none"> 1. Put the unit out of operation. 2. Eliminate the reason for the misalignment (e.g.: loose foundation, breakage of motor fastening, heat expansion of the unit's components, change of the assembly dimension E of the coupling). 3. Checking of wear. See under point of control.
	Loose screws for axial securement of hubs.	Danger of ignition due to hot surfaces.	<ol style="list-style-type: none"> 1. Put the unit out of operation. 2. Check the alignment of the coupling. 3. Tighten the screws to fasten the hubs and secure them against self loosening. 4. Checking of wear. See under point of control.
Total breakage due to shearing of the elastic insert in the area on the drive (power) side.	Break of the elastic insert due to high shock energy / overload.	Danger of ignition due to hot surfaces.	<ol style="list-style-type: none"> 1. Put the unit out of operation. 2. Disassemble the ring and remove the elastic insert. 3. Check the parts of the coupling and exchange damaged coupling parts. 4. Fit the new elastic insert and re-assemble the parts of the coupling. 5. Find out the reason of overload.
	Operating parameters not corresponding to the coupling's performance.	-	<ol style="list-style-type: none"> 1. Put the unit out of operation. 2. Check the operating parameters and select a larger coupling (consider installation space). 3. Assemble the new coupling size. 4. Check the alignment.
	Mistake in service of the unit.	-	<ol style="list-style-type: none"> 1. Put the unit out of operation. 2. Disassemble the coupling and remove the elastic insert. 3. Check the parts of the coupling and exchange damaged coupling parts. 4. Fit the new elastic insert and the parts of the coupling. 5. Provide the service staff with instructions and training.

5. Hints and instructions regarding the use in Ex hazardous areas



5.6. Breakdowns, Causes and Elimination

BREAKDOWNS	CAUSES	DANGER HINTS FOR HAZARDOUS AREAS	ELIMINATION
Premature wear of the elastic insert	Drive vibrations	Danger of ignition due to hot surfaces.	<ol style="list-style-type: none"> 1. Put the unit out of operation. 2. Disassemble the ring and remove the elastic insert. 3. Check the parts of the coupling and exchange damaged coupling parts. 4. Fit the new elastic insert and re-assemble the parts of the coupling. 5. Check the alignment and correct if necessary. 6. Find out the reason for the vibrations.
	Ambient / contact temperatures too high for the elastic insert.	Danger of ignition due to hot surfaces.	<ol style="list-style-type: none"> 1. Put the unit out of operation. 2. Disassemble the ring and remove the elastic insert. 3. Check the parts of the coupling and exchange damaged coupling parts. 4. Fit the new elastic insert and re-assemble the parts of the coupling. 5. Check the alignment and correct if necessary. 6. Check and regulate ambient / contact temperature.
	Contact, e.g., with aggressive fluids / oils, influence of ozone, too high ambient temperatures, etc., affecting a physical change in the elastic insert.	-	<ol style="list-style-type: none"> 1. Put the unit out of operation. 2. Disassemble the ring and remove the elastic insert. 3. Check the parts of the coupling and exchange damaged coupling parts. 4. Fit the new elastic insert and re-assemble the parts of the coupling. 5. Check the alignment and correct if necessary. 6. Ensure any chance of further physical changes of the elastic insert are excluded.

ATTENTION!

CITSA does not assume any liabilities or guarantees regarding the use of spare parts and accessories which are not provided by CITSA and for the damages resulting here from.